

S P A R C E S

Justin (Ning Hui) Li

To me as a designer and a computer scientist, the word "space" has two meanings. It not only represents the environment in which a design will be used, but also the range of all possible designs. Although tangible and digital designs live in different environments, the method for arriving at the ideal design is the same for either.

This begins with an exploration of the design space, by knowing the details of the problem and the users. As the landscape is slowly revealed, the goal becomes finding the best design, the highest peak. Every test of the prototype directs the team toward a higher mountain, every meeting with the client producing a better route to the top. And being at the peak - the simple exhilaration makes it worth the while.

These are my adventures in design space.

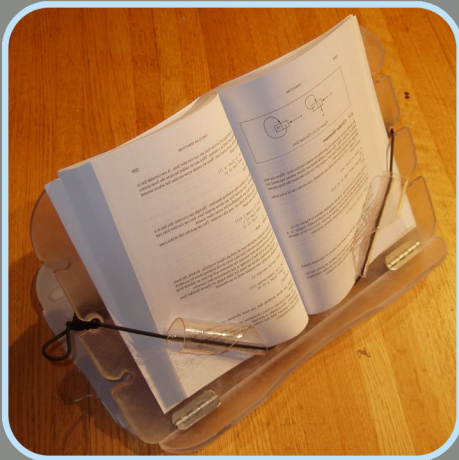

Book Holder



Interactive Oceanarium



Super Happy Fun Ball / Speech-to-Text

Doodle

Search:

Home | My Doodles | My Doodles | My Doodles

Poll "398 class time - Submersible"

Initiated by Story Bookette

Please treat the poll below as EVERY Tuesday, not just the dates shown.

[View poll](#)

Summary:
 Number of poll's dates: 2008-01-09
 Most popular: 2008-01-09
 4/10

Vote in Range:
 Last entry: 2008-01-07 00:28

What people in Chicago think about the idea of a submersible.

Results

Day	1	2	3	4	5	6	7	8	9	10	11	12	13	14	15	16	17	18	19	20	21	22	23	24	
Stephanie																									
Juanita	OK	OK	OK	OK	OK	OK	OK	OK	OK	OK	OK	OK	OK	OK	OK	OK	OK	OK	OK	OK	OK	OK	OK	OK	OK
Becca	OK	OK	OK	OK	OK	OK	OK	OK	OK	OK	OK	OK	OK	OK	OK	OK	OK	OK	OK	OK	OK	OK	OK	OK	OK
Marcus	OK	OK	OK	OK	OK	OK	OK	OK	OK	OK	OK	OK	OK	OK	OK	OK	OK	OK	OK	OK	OK	OK	OK	OK	OK
Vivianne																									

View poll

Submit | Edit | Delete

Doodle Redesign / SimpleReg



Emily / Design

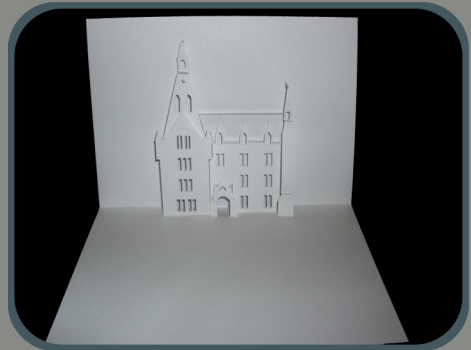

Soma Cube / University Hall

Book Holder

Team Members: Imran Karim, Clara Smart

People with tetraplegia have difficulty reading books, because of the reduced strength and dexterity in their arms. The Rehabilitation Institute of Chicago (RIC) asked us to create a book holder to keep the book open and let the pages be turned without one having to pick up the book. Additionally, the book holder should accommodate reading materials ranging from paperback novels to newspapers. By treating these as different systems within the book holder, we created a final design that not only accommodated our users but was also easy to use.

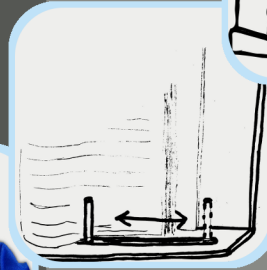
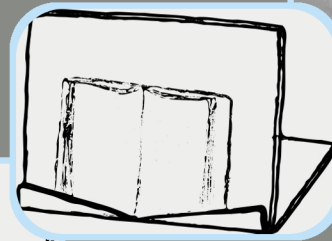
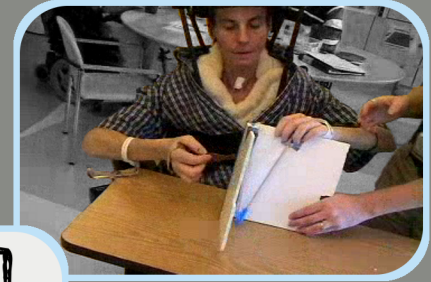

We sketched several page holders that were adjustable and would not get in the way of reading. Book holders with slanted front panels and movable front panels and movable pegs were tested with users and became the basis of our final design.



Many current book holders hold the book open but prevent easy turning of the pages. These tradeoffs are escalated for users with tetraplegia, even with the help of a typing stick.

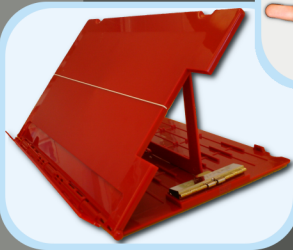

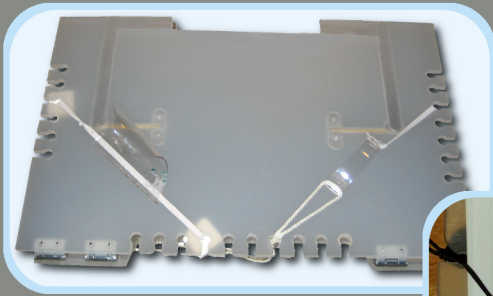

Our first prototype used elastic to hold the corners of the pages and clear pieces of plastic to guide pages in and out. Stretching the elastic adapted the book holder to stiffer books. The prototype was left at RIC for six months of field testing.

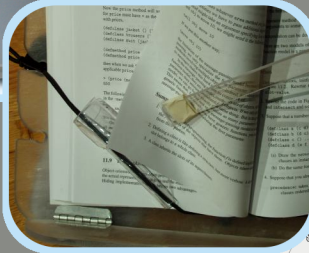

After reviewing the user feedback, we secured the elastic to the book holder and added a ledge where materials which stay open by themselves could sit. Although the final prototypes were not intended as finished products (and eventually fell apart), the users were happy with the book holders.

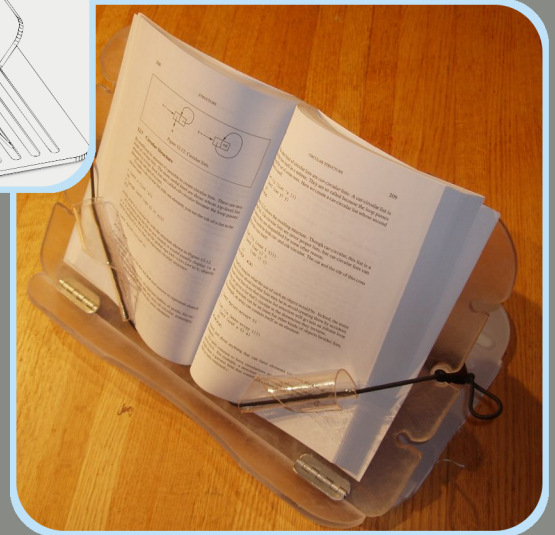

Interactive Oceanarium

Team Members: Stephanie Lo, Ilana Rosen,
Vanessa Valenzuela

As part of the John G. Shedd Aquarium's renovation of their oceanarium, they asked us to design a device to enrich the dolphins' environment and strengthen the connection between dolphins and visitors. Working with dolphins created unusual challenges for communication and safety, making it difficult to get feedback on early prototypes. Taking advantage of the dolphins' use of echolocation, we created a durable bubble-curtain generator that the dolphins could manipulate using sonar.

After observing the dolphins and talking with their trainers, we found that dolphins are very responsive to bubbles. Since bubbles represent playfulness for both dolphins and humans, our initial designs sketched out ways of using air to attract the dolphins' attention.

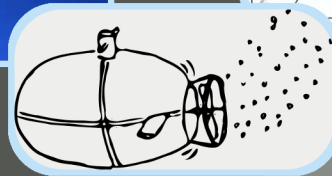
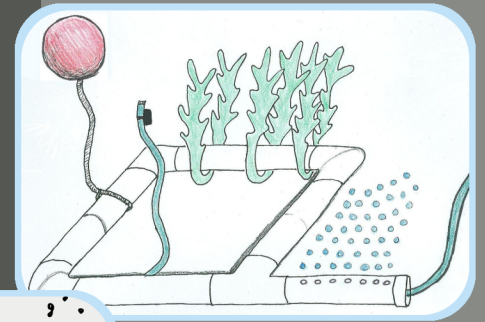
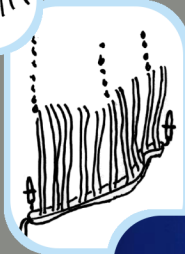
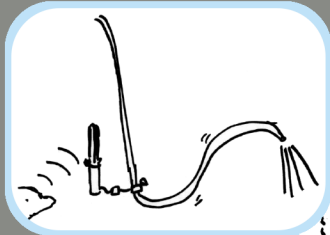

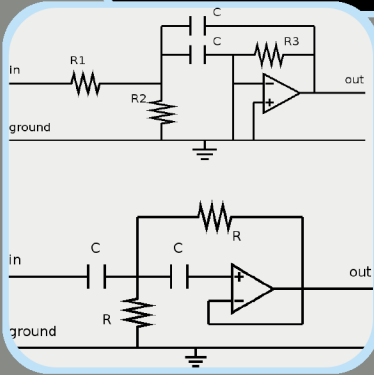
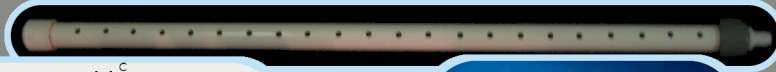

As PVC was already used in dolphin toys by Shedd Aquarium, it was the perfect material to create a cheap, durable, and replaceable body. Three circuits, a high pass filter, a band pass filter, and several logic gates were combined to receive and isolate the dolphins' echolocation signals.



When the prototype was tested in the pool, the dolphins were uncomfortable at first, and went into formation for safety. Although dolphins usually take a long time to habituate to new objects, the relatively familiar materials and bubbles soon led them to investigate the device alone and in pairs.

Speech-to-Text

Automatic transcription of speech to text (STT) is an active area of research in computer science. This project attempted to increase the transcription accuracy of a YouTube video using its metadata – the title, description, user comments, and related video. We used CMU's Sphinx speech recognition engine.

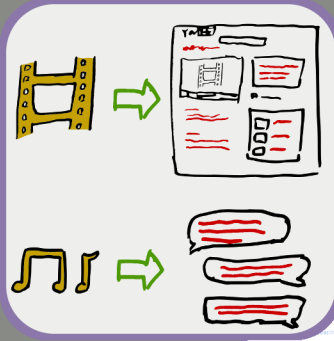

...me how 'i 'im 're 'fr 'ft 're 'gion 'oh 'that 'the 'trow 'thru 'two 'w
...y 've 'you 'added 'also 'alt 'alice 'never 'ending 'Anything
... 'began 'beginning 'betwe 'best 'better 'bill 'bit 'bitch 'called
... 'change 'chapter 'children 'caring 'confusion 'conversations 'cook 'Course
... 'curious 'dance 'dare 'dear 'deat 'do 'done 'door 'dormouse
... 'enough 'everything 'eyes 'face 'for 'feet 'felt 'finished 'fishbone 'fishy
... 'th 'gave 'getting 'the 'and 'great 'going 'gore 'grow 'gryphon
... 'hate 'hasty 'hatter 'head 'has 'heard 'house 'hurry
... 'jury 'keep 'leg 'new 'leave 'become 'the 'live 'labor 'mad
... 'minute 'mock 'moment 'mouse 'name 'nothing
... 'oh 'opened 'people 'perhaps 'please 'please 'poor 'queen
... 'question 'quite 'rabbit 'ran 'rather 'red 'really 'remark 'remember
... 'replied 'round 'sat 'saying 'see 'seemed 'sight 'vienna 'w
... 'something 'soon 'soft 'soup 'speak 'spoke 'suddenly 'suppose 'sure 'surre
... 'things 'think 'thought 'all 'tone 'took
... 'turtle '... 'voice 'waited 'walked 'white '... 'wish 'wishes

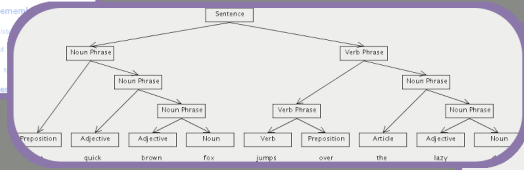

After finding documents containing words relevant to the video, the program builds a language model specific to the topic of the video. This, together with a first pass transcript of the video and a pronunciation dictionary, is supplied to Sphinx. The marginally better results suggest that the accuracy of the transcript is correlated more highly with the quality of audio than with the language model gathered in this manner.

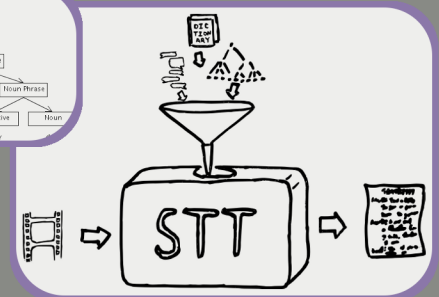

Doodle Redesign / SimpleReg

Human Computer Interaction Projects

Human computer interaction (HCI) investigates how digital components are integrated into a human environment. Since computers offer more interactivity and dynamic content than physical mediums, principles used for the latter do not transfer well. An interaction designer's job is to minimize the impedance the system creates by selecting the right metaphors through which the users will understand the interface.

Doodle

Poll "McCormick Advisor Meeting"

This screenshot shows a Doodle poll interface. At the top, it displays the poll title and a description. Below this, there is a table for selecting dates and times. The table has columns for days of the week and rows for different time slots. Each cell contains a small calendar icon. To the right of the table, there are checkboxes for 'I am free' and 'I am not free'. Below the table, there is a 'Participate' button and a 'Link to poll' link. At the bottom, there is a question: 'On a scale of 1 to 5 with 1 being the easiest, How well were you able to understand how to vote?'. Below this question are four horizontal bars representing the distribution of answers: 1 (shortest), 2, 3, and 4 (longest).

On a scale of 1 to 5 with 1 being the easiest, How well were you able to understand how to vote?

Answer



This screenshot shows a Doodle poll interface for 'Poll 398 class time - Submersible'. It includes a poll title, a description, and a table for selecting dates and times. The table has columns for days of the week and rows for different time slots. Each cell contains a small calendar icon. To the right of the table, there are checkboxes for 'I am free' and 'I am not free'. Below the table, there is a 'Participate' button and a 'Link to poll' link. At the bottom, there is a question: 'On a scale of 1 to 5 with 1 being the easiest, How well were you able to understand how to vote?'. Below this question are four horizontal bars representing the distribution of answers: 1 (shortest), 2, 3, and 4 (longest).

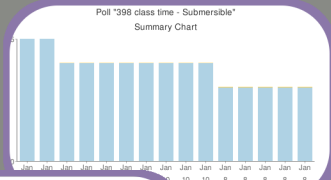

This screenshot shows a poll page with a name field containing 'Justin'. Below the name field, there is a calendar for January 2008 with dates 8 and 10 selected. To the right of the calendar, there is a list of times available on 2008-01-08. Below the list, there is a 'Participate' button and a 'Link to poll' link. At the bottom, there is a question: 'On a scale of 1 to 5 with 1 being the easiest, How well were you able to understand how to vote?'. Below this question are four horizontal bars representing the distribution of answers: 1 (shortest), 2, 3, and 4 (longest).

Doodle Redesign

Doodle, a website for coordinating meetings, is problematic because it uses a non-standard calendar format, requires horizontal scrolling, and generally lacks instructions, creating a non-intuitive interface for the users. We eliminated the first two problems by making the calendar consistent with users' expectations and added a dynamically generated graph to show poll results at a glance.

SimpleReg

While regular expressions (regex) provide a powerful way of finding and replacing text, its usage is limited by its arcane syntax. The goal of this project was to create a graphical user interface to make regex more accessible.

The interface simplifies regex by suggesting common categories, such as words or numbers. The results are highlighted to show users whether the regex expresses the correct text. Testing the prototype, however, revealed that the concept was too foreign to many users. We concluded that the program would be more effective if it learned from examples replacements given by the user.

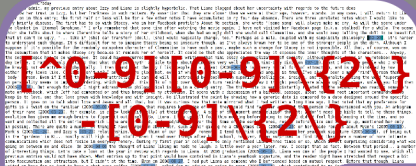

Match:

-

- any character
- any digit
- any letter
- any letter or digit
- any punctuation

add new collapse all run all

Match: [] date

For # of times: 2 add

Matching

- 1. [number] (2)
- 2. -(1)
- 3. [number] (2)

Add replacing: XX

add replacement

Replacing

- 1. (match) XX
- 2. (match 2) -
- 3. (match) XX

Pattern regex: /([0-9]{2})([0-9])([0-9])([0-9])/g

SimpleReg

create button

Match: [] date

For # of times: 2 add

Matching

- 1. [number] (2)
- 2. -(1)
- 3. [number] (2)

Add replacing: XX

add replacement

Replacing

- 1. (match) XX
- 2. (match 2) -
- 3. (match) XX

Pattern regex: /([0-9]{2})([0-9])([0-9])([0-9])/g

Michelle Callahan
Vazquez, Antonio
Winters, Isiah
Christensen, Riley
Klein, Sofia
Chase, Caroline
Shaffer, Steven
Simpson, Hunter
Randall, Justin
Gordon, Lauren

Commands

- New Text: Michelle Callahan
- Old Text: Callahan, Michelle
- Add Text: Gordon, Lauren
- Add Text: Randall, Justin
- Add Text: Simpson, Hunter

Repeat Action

Rule:	Example:
Rearrange: Proper Noun1, Proper Noun2	Change: Callahan, Michelle
To: Proper Noun2 Proper Noun1	To: Michelle Callahan

Emily / Design

Ambigrams

Made popular in Dan Brown's novel *Angels and Demons*, ambigrams are literally words (-gram) that can be read in two (ambi-) ways. Designing an ambigram is like putting together a jigsaw with shape-shifting pieces; the pieces must be forced into the necessary shape before the puzzle is complete. While the letters in an ambigram must form a word, shaping the letters requires not only artistry but also an understanding of human perception.

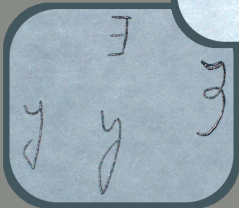
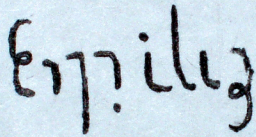
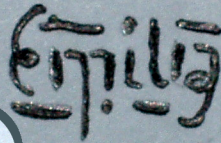

Emily

Turning the name 'Emily' into an ambigram came easily. The descender of the 'y' was easily reshaped to form the strokes of the capital 'E'. More problematic was combining the 'm' and the 'i'. Because fitting the calligraphic style required an extended space, omitting the 'i' made the ambigram more readable despite the ambiguous spelling.

Design

Making an ambigram starts with a search for common typographic features in the normal and inverted letters. For the word 'design', aligning the ascender and descender of 'd' and 'g' requires merging the first and last two letters into one glyph.

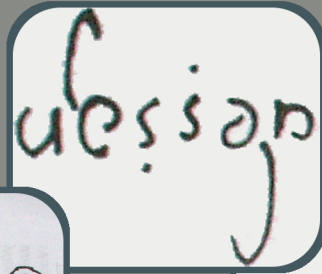
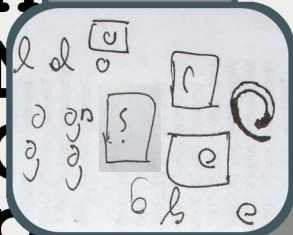
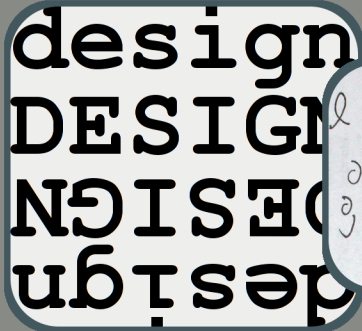

A vector graphics application converts the letters into bezier curves, allowing individual sections of a glyph to be manipulated separately. The merged 'de' is connected with a squiggly 'i' to create a consistent typeface.



Soma Cube / University Hall

Origami

Although paper is 2-dimensional, it can be used to create intricate 3-dimensional objects simply from paper. Modular origami folds multiple pieces of paper into interlocking units, from which complex mathematical polyhedra can be assembled. Origamic architecture is the reverse, using one sheet of paper and cutting only where necessary. These form the outline of buildings or geometric patterns when the paper is folded.

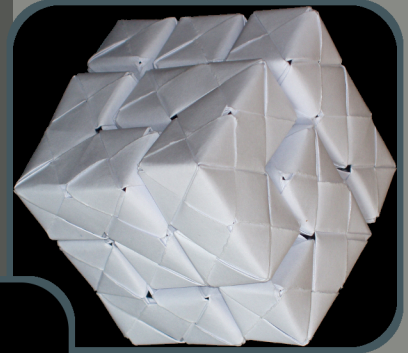
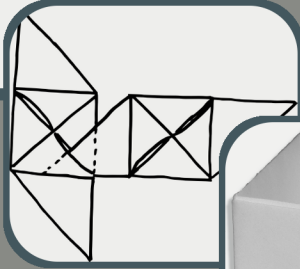
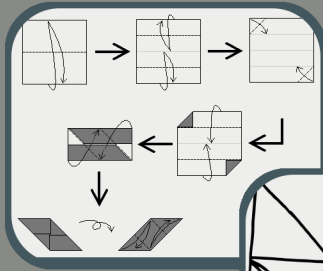

Soma Cube

A soma cube is a 3-dimensional tangram, with each piece being made up of three or four cubes. Although the shape of each piece is complex to fold, the basic cube is not. Modular origami uses one piece of paper to form one side of the cube. Each module has flaps and pockets to lock it in place with the other modules, building the larger cube side by side.



University Hall

To recreate a building in origami architecture, the original building is photographed and measured. Because only one piece of paper is used, each feature must be framed by either a paper frame or a blank space. Shifting the feature along the paper changes how far it will stand out from the background.

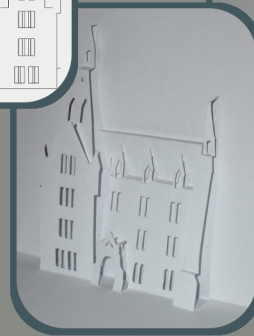
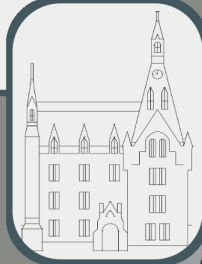
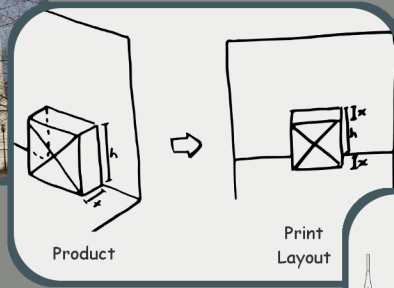

A geometry program is used to draw the design in reverse, so the guidelines are hidden on the inside of the product. Folding the card requires care to coax the paper from its original flat form and to avoid forming creases in undesired places. The result is an elegant pop-up of the building.



Hello there

I hope you've enjoyed my portfolio, and would like to know more about me.

My first love in academics is computer science; I am always amazed by how I can create a virtual reality on my computer. Despite this declaration, however, I am interested in many other fields, which caused me endless frustration when I picked courses. Besides computer science and design, I take great pleasure in teaching people, and have actively sought opportunities to share my enthusiasm for learning.

In my free time I write both programs and journals, although having a book in one hand and a cup of coffee in the other would make me very content as well. I also enjoy the outdoors, and am an amateur hiker, camper, cyclist, and rock climber. These usually provide me with ample opportunity to be at the right place at the right time to capture the beautiful scenery.

Acknowledgments

I would like to thank Professors Don Norman, Bryan Pardo, Penny Hirsch, and Ann McKenna for helping me find the direction for this portfolio and offering critique during the process. Special thanks to Eugenia Gabrielov and Ryan Murphy, who suffered my pestering for feedback many times.

(0,0)
/))
- " " -